

Design and Fabrication of a Magnetic Stirrer for Bio-Diesel Production

Sule Salisu¹, Joseph I. Achebo² and Alexander Akene^{3*}

¹Department of Mechanical Engineering, Petroleum Training Institute, Effurun, Nigeria.

²Department of Production Engineering, University of Benin, Benin City, Nigeria. ³Department of Mechanical Engineering, Federal University of Petroleum Resources, Effurun, Nigeria.

Corresponding Author: *akene.alexander@fupre.edu.ng

Abstract

As an after effect of expanding vitality request and the contamination issues brought about by the utilization of non-sustainable power source, for example, petroleum products, the utilized of vegetable oils and their subordinators as option for diesel fuel is important. The utilization of biodiesel as a substitute for ordinary vitality source is of incredible ecological and affordable worth. Is in this intrigue, this examination work titled plan and manufacture of an attractive stirrer for bio-diesel creation was done. The accompanying materials and hardware which incorporate; PVC versatile box, glass piece, mix bar, neodymium magnet, 12V DC rotor, potentiometer, switch, AC female connector port, AC connector, DC to DC support converter, LM317, Vero board, and hardware wire were utilized in this examination work. The framework comprises of significantly three basic units which incorporate controller unit, yield unit and force unit. The controller unit comprises of a movable straight controller IC (LM317) which gets the voltage (12V DC) and fluctuates it between 10V DC and 12V DC that forms it and sends the voltage to the yield unit. The yield unit comprises significantly of our rotor installed with magnets and a warmer. The force unit comprises of an AC connector intended to change over 220V AC to 5V DC, 1A. The attractive stirrer was created and the aftereffects of execution test did indicated that the genuine force in the stirrer was 6.25 watts. Also, a torque of 353.16 N, an effectiveness of 56.8%, an expected time required for complete response of the framework was 7 hours (25200 seconds), the force contribution to attractive stirrer was 11 watts, and the net vitality conveyed during 7 hours was 277.2 KJ. With an effectiveness of 56.8% acquired, the exhibition of the created attractive stirrer is palatable.

Keywords: Magnetic stirrer, bio-diesel, renewable energy, sustainability, net energy,

1. Introduction

The utilization of petroleum derivative as a wellspring of vitality has incredibly made mischief nature and more damage to the biological system; in this way, there is requirement for an increasingly proficient and eco-accommodating technique for

vitality accessibility. Additionally, inaccessibility and fast increment in expenses of customary vitality supply required the requirements for elective vitality sources that is inexhaustible, modest and similarly feasible (Zhang *et al.*, 2014;

Orhorhoro, et al., 2017; Orhorhoro and Erameh, 2019; Ebunilo et al., 2016). Biodiesel is an inexhaustible and supportable vitality source got from different organic sources which can be utilized in unmodified diesel motors (*Orhorhoro and Oyejide, 2020; Jain, and Sharma, 2010*). Additionally, biodiesel can be blended in any amount with mineral diesel to deliver a biodiesel mix or can be works in unblended structure. Much the same as oil diesel, biodiesel works in the pressure start (diesel) motor and essentially need next to no or no motor alteration in light of the fact that nearly their properties are comparable with that of hydrocarbon diesel (*Mielenz et al., 2009*). The utilization of biodiesel in traditional diesel motors brings about extensive lessening in the release of unburned hydrocarbons, CO, and particulates. As of now there is countless winning biodiesel creation plants worldwide and furthermore tremendous numbers are under development to supply the developing worldwide necessity (*Azam, et al., 2005; Belewu, et al., 2017; Lawan and Serder, 2019*).

Moreover, inquire about works completed on attractive stirrers gave an extensive perspective into the comprehension of the essentials for the utilization of attractive stirrers for the creation of bio-diesel. One bit of hardware that is generally utilized in science research centers is the attractive stirrer. An attractive stirrer is a research center gadget that utilizes a pivoting attractive field to create a scene bar inundated in a fluid to turn rapidly, subsequently mixing it. For this situation,

the turning field is either made by a pivoting magnet or a lot of fixed electromagnets, set underneath the vessel with the fluid (*Canakci, and Van Gerpan, 1999; Dube, et al., 2007; Ghobadia, 2012*). Ordinarily, they are favored over rigging driven mechanized stirrers since they are calmer, progressively proficient, and have no moving outer parts to break or destroy (*Saharma, et al., 2016; Shrirame, et al., 2011*). Attractive mix bars function admirably in glass vessels generally utilized for compound responses, as glass doesn't apparently influence an attractive field. It utilizes a mix bar and a mix bar is the attractive bar set inside the fluid which gives the mixing activity (*Otake, et al., 2008*). The mix bars as an instrument have a movement that is driven by another turning magnet or get together of electromagnets in the stirrer gadget, underneath the vessel containing the fluid. Albeit, different stirrer, for example, mechanical stirrer, turbines, grapple stirrer, helical stirrer and so forth., has been utilized to improve response and diminish biodiesel creation time yet adequate work has not been done with attractive stirrer therefore this exploration work that focused on the plan and manufacture of a rearranged attractive stirrer from privately sourced materials for the mixing of bio-diesel during creation.

2. Materials and Method

2.1 Materials

In this research work, non-edible oil samples such as castor oil was used. The castor oil was purchased from local a market in Ondo State of Nigeria. Sodium

hydroxide with percentage purity (99%) and methyl alcohol (catalyst) with percentage purity 99.5 % were used in this research work. Although, castor oil is used as lubricant in engines but recent research work has shown that castor oil can be used as bio fuel (*Berman, et al., 2011*). It can be processed into a good biodiesel that can be blended with diesel for the same reason (*Mohammed, et al., 2008*). The seeds cannot be used for animal feed because it contains extremely poisonous substances that remain in the press cake.



2.1.1 Properties of Castor Oil



It possesses the following properties (*Saharma, et al., 2016*);

- i. Apart from castor oil that has high ricinoleic acid content of over 85%, no other vegetable oil contains so high a proportion of fatty hydroxyacids.
- ii. Castor oils has unsaturated bond
- iii. It has high molecular weight
- iv. It has low melting point
- v. It has low solidification point that make it industrially useful

Other materials and equipment used in this research work are shown in Table 1.

Table 1. Description of Materials and Equipment Used

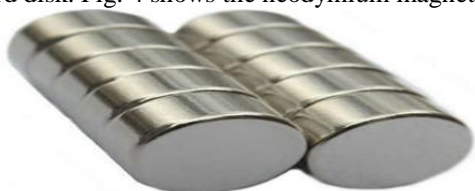
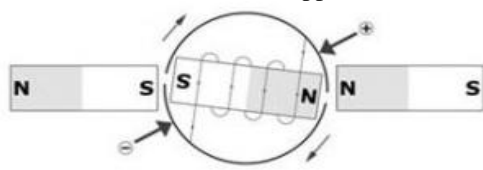
S/N	Materials/Equipment Used	Description
1.	PVC adaptable box	<p>The PVC adaptable box shown in Fig. 1 was used for encasing the developed magnetic stirrer and making it presentable and easy to use while covering all the wiring and circuitry.</p>  <p style="text-align: center;">Fig. 1 PVC Adaptable Box</p>
2.	Glass slab	<p>The glass slab as depicted in Fig. 2 was used to transmit heat from our heater to the container containing the fluid.</p>  <p style="text-align: center;">Fig.2 Glass Slab</p>
3.	Stir bar	<p>The stir bar shown in Fig.3 served as the magnetic bar placed within the liquid which provides the stirring action. The motion of the stir bar is driven by another rotating magnet or assembly of electromagnets in</p>

		<p>the stirrer device, beneath the vessel containing the liquid.</p>  <p style="text-align: center;">Fig.3 Stir Bar</p>
4.	Neodymium magnets	<p>Neodymium magnets were selected in this research work because they are the strongest type of permanent magnet commercially available. Besides, it possess strong magnetic field. It was gotten from a computer hard disk. Fig. 4 shows the neodymium magnets.</p>  <p style="text-align: center;">Fig. 4 Neodymium Magnets</p>
5.	12V DC ROTOR	<p>In the DC motor (Fig. 5) used in this research work, there is a fixed set of magnets in the stator. It has an armature with one or more windings of insulated wire wrapped around a soft iron core. This iron core concentrates the magnetic field produced. The ends of the wire winding are connected to a commutator that powers up and energizes each armature coil. The strength of the electromagnetic field thus created, depends upon the amount of current passing through the coil, its size and the material around which it is wrapped.</p>  <p style="text-align: center;">Fig. 5 12 DC Rotor</p>
6.		<p>The potentiometer shown in Fig. 6 was used to directly control significant power (more than a watt), since the power dissipated in the potentiometer would be comparable to the power in the controlled load.</p>  <p style="text-align: center;">Fig. 6 Potentiometer</p>
7.	Switch	<p>The switch was used to boot up the system and turn off the system. The female adapter port was used to connect AC power to the system with an adapter plug. The system requires a regulation system for voltage which regulates the speed of the rotor. So LM317 is needed to make sure any voltage going to the controller is regulated between 10vdc to 12V DC.</p>

		<p style="text-align: center;">LM317 Pinout</p> <p style="text-align: center;">Fig. 7 LM317 layout</p>
8.	AC Adapter	<p>It converts 220V AC to 5V DC by taking input as 220V and gives output of 5V. The circuit operates under DC voltage. It operates under the principle of full wave rectification. Fig. 8 shows the resultant output waveform of the system.</p> <p style="text-align: center;">Fig. 8 Resultant Output Waveform of the System</p>
9.	Circuitry wires	<p>These wires are basically for connecting components together in the circuit. They are quite ductile and carry optimal signals needed for the proper functioning of all the components in the circuit.</p>
10.	Vero boards	<p>The Vero board shown in Fig. 9 acts as a housing and a base for the components. This is where all the components are mounted and connected.</p> <p style="text-align: center;">Fig. 9 Vero Board</p>

2.2 Methods

The flow chart of the system showing each unit is depicted in Fig. 10.

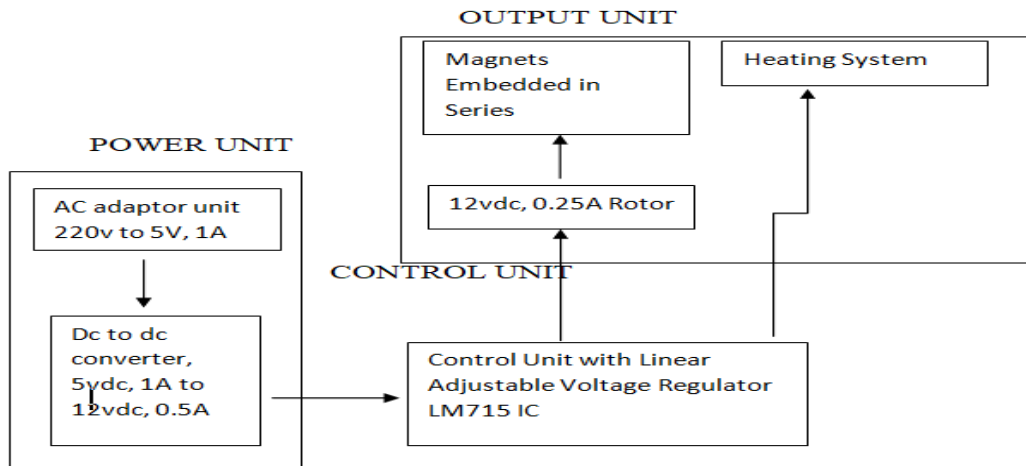

Fig. 10 Flow Charts of the System showing each Unit

2.2.1 Design Consideration

The following factors were considered;

- i. Availability of materials
- ii. Less weight
- iii. Low cost
- iv. Magnetic properties

2.2.2 Construction of the Magnetic Stirrer

The construction of the magnetic stirrer includes the selection, processes, test and evaluation of the materials required for the research work. The DC rotors embedded with magnets are placed in the stirrer which creates a magnetic field that in turns rotates the stirrer as the rotor rotates. The system consists of majorly three simple units which includes

- i. Controller Unit
- ii. Output Unit and
- iii. Power Unit.

Controller Unit

The controller unit consists of an adjustable linear regulator IC (LM317) which receives the voltage (12V DC) and varies it between 10V DC and 12V DC that processes it and sends the voltage to the output unit. The LM317 was controlled by some set of resistors and potentiometer to ensure it varies the voltage between the expected ranges for an optimum performance.

Output Unit

The output unit consists majorly of our rotor embedded with magnets and a heater. The rotor received command from the controller unit where it is converted to magnetic energy which in turns sets the rotor and stir bar in motion. The heater the system simultaneously as the fluid is being stirred.

Power Unit

The power unit consists of an AC adaptor designed to convert 220V AC to 5V DC, 1A. The 5V DC was in turn converted to 12V DC with the use of a DC to DC boost converter. The key principle that drives the boost converter is the tendency of an inductor to resist changes in current by creating and destroying a magnetic field. In a boost converter, the output voltage is always higher than the input voltage. When the switch is closed, current flows through the inductor in clockwise direction and the inductor stores some energy by generating a magnetic field. Polarity of the left side of the inductor is positive. So in this case we obtain the current through the inductor using Equation (1) to Equation (4).

$$0 < t < D$$

$$(1)$$

$$V_s = L di(t)/dt$$

$$(2)$$

$$I_l(t) = (V_s/L)t + C$$

$$(3)$$

$$\delta i_l = (V_s/L)DT$$

$$(4)$$

The voltage input in magnetic stirrer (V) = 220v

The current input in the magnetic stirrer (I) = 50mA

The power input in magnetic stirrer is given by Equation (5)

$$P = VI$$

$$(5)$$

$$P = 220 \times 50 = 11 \text{ watts}$$

The torque = 353.16Ns

But,

$$P = T\alpha$$

$$(6)$$

where,

P= Power output

T= Torque

α = Angular velocity

Thus,

$$P = 353.16 \times 0.017 \times 15000/14400 = 6.25W$$

Therefore, actual power in the stirrer = 6.25W

The efficiency of the magnetic stirrer is given by Equation (7)

$$Efficiency (\eta) = \frac{Power Output}{Power Input}$$

$$(7)$$

$$Efficiency (\eta) = \frac{6.25}{11} = 56.8\%$$

The estimated time required for completing the reaction = 7hours = 25200s

The net energy delivered during 7hours was calculated from Equation (8).

$$E_{Net} = Power input in magnetic stirrer \times Time required$$

$$(8)$$

$$E_{Net} = 11 \times 25200 = 277200J = 277.2kJ$$

Estimated quantity of materials processed = 4g

The net energy supplied for processing of materials during 7hours = Net Energy

delivered during 7hours/ Quantity of materials processed = $277.2/4 = 69.3\text{KJ/g}$

2.2.3 Configuration of the Magnetic Stirrer

The orthographic view of the magnetic stirrer is shown in Fig. 11.

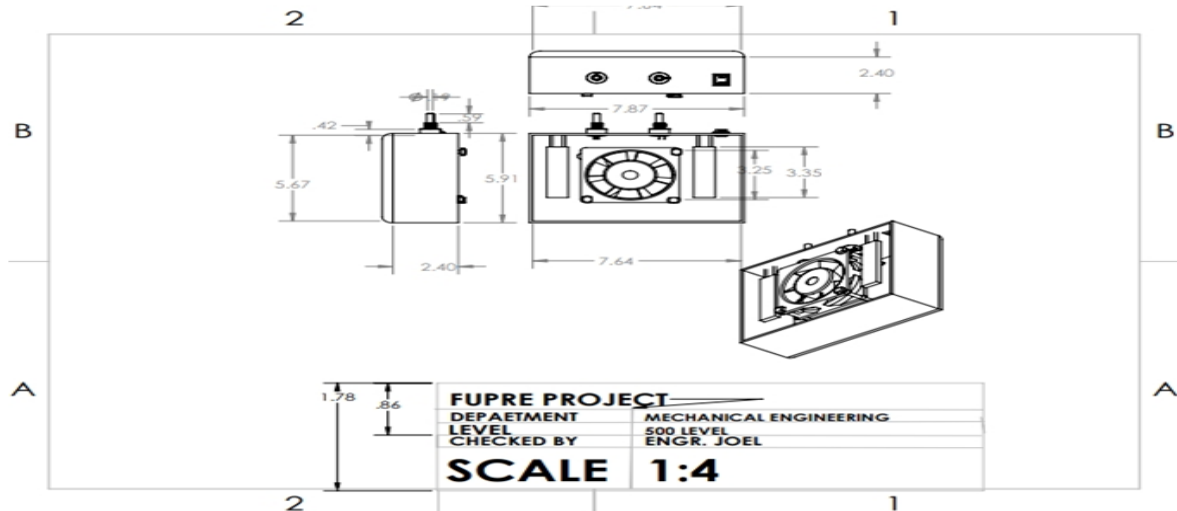

Fig. 11 Orthographic View of the Magnetic Stirrer

Fig. 12 shows the isometric view of the magnetic stirrer.

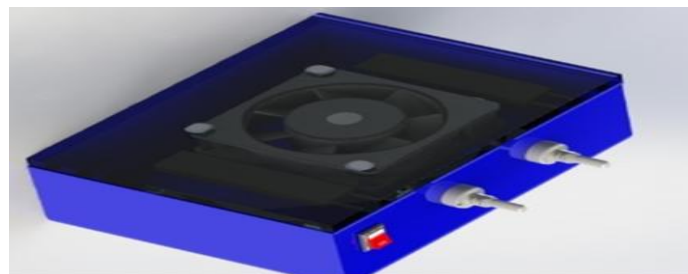

Fig. 12 Isometric View of the Magnetic Stirrer

Fig. 13 shows the constructed magnetic stirrer.

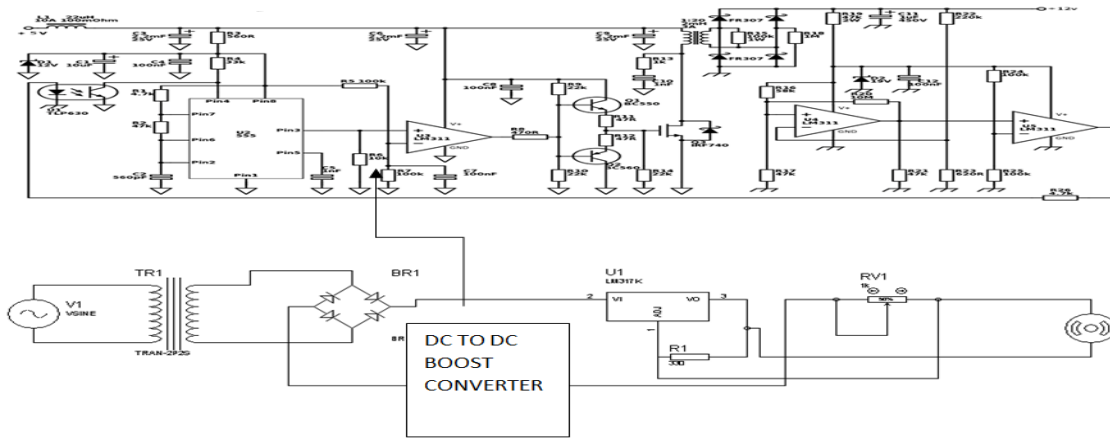

Fig. 13 The Constructed Magnetic Stirrer

2.2.4 Description of the Developed Magnetic Stirrer

The mix bar pivots at various speeds and can blend volumes up to one liter. Since just a little magnet bar which can undoubtedly be cleaned and disinfected must be put inside the example, the danger of tainting is limited. The attractive mix bars function admirably in glass vessels and glass is a material that doesn't influence an attractive field. The mix bar has a constrained size that is the reason it very well may be utilized for generally little examinations (under 4 liters). In spite of the fact that, it can experiences issues with gooey fluids and thick suspensions. The plastic instance

of the gadget fills in as a decent separation from spills. The attractive stirrer has no moving parts and utilizes an attractive field. The lodging of the most attractive stirrers is made of polypropylene and the mix bar is made of ferrite encased in polypropylene. Two bar magnets adjust in equal bring inverse shafts of every magnet together. The stirrer with one turning magnet under the outside of the compartment is driven by the engine with one mixing magnet at the base of the liquid holder. The circuit outline is appeared in Fig.



14

Fig. 14 Circuit Diagram

2.2.5 Performance Test

Continuity Test

The continuity test was performed to ensure electrical continuity between components mounted on the circuit board.

Short Circuit Test

The short circuit test was done to ensure that all short-circuited circuits are isolated from bridging points. All the components soldered on the Vero board had to be tested. It is usually caused by spill of solder led on terminals that are supposed to be separately soldered.

Open Circuit Test

The open circuit test was carried out to discovered areas of the circuitry that were not soldered.

Operational Test

The purpose of the operational test was to determine the magnetic stirrer machine is working and responding to inputs. The voltage test was carried out severally to ascertain the voltage at different points in the network. A multi-meter was used in carrying out this test. The magnetic stirrer was tested to check its functionality and the result was satisfactory.

Free Fatty Acid Test

In order to determine the percentage of free fatty acid (FFA) in the castor oil, titration was carried out using aqueous sodium hydroxide. The castor oil is initially first mixed with methanol and this was followed by a mixture of sodium hydroxide (NaOH)

and water is added for complete reaction to takes place. The pH was monitored continuously to check if free fatty acid was successfully utilized.

3. Results and Discussion

The configured magnetic stirrer shows that the actual power in the stirrer was 6.25W. Besides, a torque of 353.16N, an efficiency of the magnetic stirrer of 56.8%, the power input in magnetic stirrer was 11 watts, and the net energy delivered during 7 hours was 277.2 KJ. The efficiency of 56.8% obtained showed significant improvement in the magnetic stirrer. The efficiency equally indicated a satisfactory performance. Table 2 shows the results of the free fatty acid test. Table 3 shows the duration and quantity of castor oil properly stirred with the magnetic stirrer. Fig. 15 shows the variation of milliliter titration, percentage free fatty acid (%FFA), pH and Sodium hydroxide. As depicted, there was steadily increased in %FFA as titration volume increases. Also, the pH throughout was approximately 9 and this is an indication of completely reaction of FFA. As reported by Saharmaet *al.*, 2016, a pH of about 9m signifies all of the FFA has been reacted. The performance test results of magnetic stirrer showing duration and quantity properly processed is shown in Fig. 16. As depicted in Fig. 16 an average processing time of 3.874 hours was required for an average mass of 2.273g of castor oil. Also, the capacity of the magnetic stirrer was satisfactory because an average machine throughput capacity of

0.5882 g/hr. was determined which is sufficient for the system operation.

Table 2 Results of the Percentage Free Fatty Acid (%FFA)

S/N	ml Titration	Percentage Free Fatty Acid (%FFA)	NaOH per ml	(grams)	pH (m)
1	1.00	0.605582	16.205		8.89
2	1.50	1.052490	18.021		9.00
3	2.00	1.390255	21.015		8.75
4	2.50	1.706894	22.655		9.01
5	3.00	1.998579	23.996		8.99
6	3.50	2.312568	25.855		9.02
7	4.00	2.779856	28.023		9.00
8	4.50	3.108654	30.099		9.00
9	5.00	3.457890	31.967		9.01
10	5.50	3.950894	32.568		8.99

Table 3 Performance Test Results of Magnetic Stirrer showing Duration and Quantity Properly Processed

S/N	Mass of Castor Oil (g)	Duration of Processing (Hrs.)	Capacity of the Magnetic Stirrer (g/hr.)
1	0.50	0.88	0.568
2	1.00	1.81	0.552
3	1.55	2.35	0.660
4	1.85	3.21	0.576
5	2.15	3.45	0.623
6	2.55	4.40	0.580
7	2.85	4.85	0.587
8	3.00	5.08	0.591
9	3.28	5.71	0.574
10	4.00	7.00	0.571
Σ	22.73	38.74	5.882
Ave.	2.273	3.874	0.5882

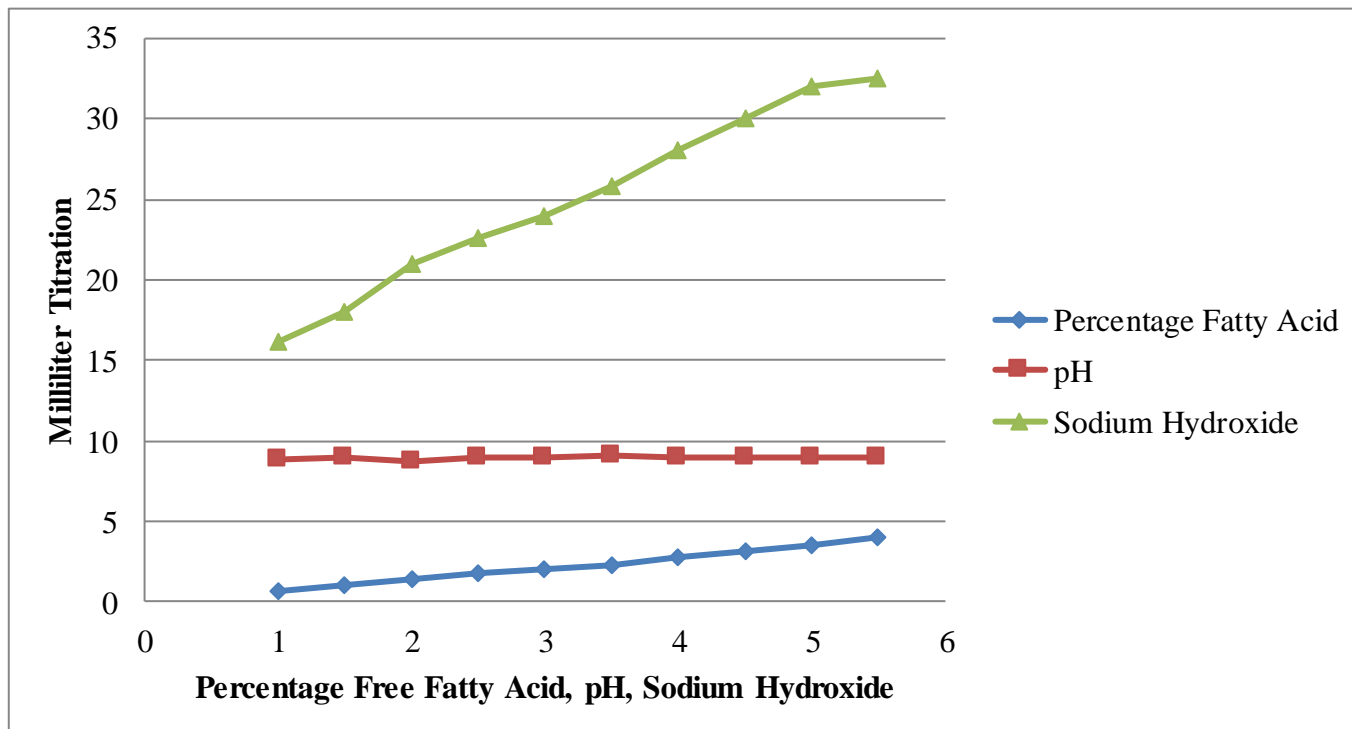

Fig. 15 Graph of milliliter against Percentage Free Fatty Acid, pH and Sodium Hydroxide

Fig. 16 Performance Test Results of Magnetic Stirrer showing Duration and Quantity Properly Processed

Conclusion

Biodiesel as an alternative fuel for diesel engines is becoming increasingly important due to diminishing petroleum reserves and the environmental consequences of exhaust gases from petroleum-fueled engines. To replace diesel as a future prospective fuel, biodiesel has to compete economically with petroleum diesel fuels. To achieve this, an improved stirrer that can improve reaction and reduce biodiesel production time is required. In this research a magnetic stirrer was successfully developed. The developed magnetic stirrer performance was satisfactory with an efficiency of 56.8%, and with an average processing time of 3.874 hours for an average mass of 2.273g of castor oil. Therefore, the developed magnetic stirrer can be used for both small and medium scale bio-diesel industries in Nigeria.

References

- Azam, M.M., Waris, A. and Nahar, N.M., 2005 Prospect and potential of fatty acid methyl esters of some non- traditional seed oil for use as a biodiesel in India. *Biomass and Bioenergy*, 29: 293-302
- Belewu, M.A., Adekola, F.K., Adebayo, G.B., Ameen, O.M., Auhammed, N.O., Alaniyan, A.M., Adekola, O.F. and Musa, A.K., 2017. Physico-chemical characteristics of oil and biodiesel from Nigerian and Indian *Jatropha curcas* seeds. *International Journal of Biological Chemical Sciences* 4(2): 524-529
- Berman, P., Nizri, S. and Wiesman, Z., 2011. Castor oil biodiesel and its blends as alternative fuel. *Biomass and Bioenergy*, 35: 2861-2866.
- Canakci, M. and Van Gerpan, J., 1999. Biodiesel production via acid catalysis. *Trans ASAE*. 45(5):1203-1210
- Dube, M.A., Tremblay, A.Y. and Liu, L., 2007. Biodiesel production using a membrane reactor. *Bio-resource Technology* 98: 639-647
- Ebunilo, P. O., Orhorhoro, E. K. and Adegbayi, O. A. 2016. Investigation of the purification of biogas from domestic wastes using local materials in Nigeria, *International Journal of Scientific & Engineering Research* 7(2): 505-515.
- Ghobadia, B., 2012. Liquid biofuel potential and outlook in Iran: Renewable and Sustainable Energy Reviews. 16: 4379-4384.
- Jain, S. and Sharma, M.P., 2010. Renewable Sustainable Energy Reviews 14:667-672
- Lawan, M.M. and Serder, S., 2019. Analysis and characterization of biodiesel production from glycine max seed oil using alkali catalyst,

- FUDMA Journal of Sciences (FJS), 3(1): 84 – 90
- Mielenz, J.R., Bardsley, J.S. and Wyman, C.E., 2009. Fermentation of soybean hulls to ethanol while preserving protein value. *Bioresource Technology*, 100(14): 3532-9
- Mohammed, H., Chakrabarti, H. and Ahmad, R., 2008. Transesterification studies on castor oil as a first step towards its use in bio diesel production, *Pak. J. Bot.*, 40(3): 1153-1157
- Orhorhoro, E. K. and Erameh, A. A., 2019. Performance evaluation of the effect of temperature and pH on biogas yields from anaerobic co-digestion of food waste and pig dung, *Igbinedion University Research Day and Conference, Nigeria, 2019*.
- Orhorhoro, E. K. and Oyejide, J. O., 2020. Modelling of Biogas Yield from Anaerobic Co-digestion of Food Waste and Animal Manure using Artificial Neural Networks, *applications of modeling and simulation*, 4:81-88
- Orhorhoro, E. K., Ebunilo, P. O. B. and Sadjere, E. G., 2017. Experimental determination of effect of total solid (TS) and volatile solid (VS) on biogas yield, *American Journal of Modern Energy*, 3(6): 131-135.
- Otake, R., Yamada, T., Hirayama, R., Fujisaki, K., Shimasaki, S. and Taniguchi, S., 2008. Effects of Double-Axis Electromagnetic Stirring in Continuous Casting, *44(11): 4517–4520*
- Saharma, S., Upadhyay, Y.P., Sharma, R.B., Pal, A., 2016. Production of Biodiesel by Mechanical Stirrer Technique and Optimising its Yield, *International Journal of Emerging Technology and Advanced Engineering*, 3(8):358-361
- Shrirame, Y.H., Panwar, N.L. and Bamniya, B.R., 2011. Bio Diesel from Castor Oil - A Green Energy Option, *Low Carbon Economy* 2: 1-6
- Zhang, C., Su, H., Baeyens, J. and Tan, T., 2014. Reviewing the anaerobic digestion of food waste for biogas production. *Renewable and Sustainable Energy Reviews* 38:383–392.