

Design Consideration and Analysis of an Improved Feather Plucking Machine for Domestic Applications

¹Ashiedu, F. I., ²Akpan, E. E., ³Oboh A. E. and ⁴Samuel, O.D.

^{1,4}Department of Mechanical Engineering, College of Technology, Federal University of Petroleum Resources, Effurun, Delta State, Nigeria

²University of Derby, Faculty of Engineering and Technology, Market on the Street Campus, Derby, Derbyshire, DE22 3AW

³Department of Mechanical Engineering, Faculty of Engineering and Technology, University of Uyo, Akwa Ibom State, Nigeria

¹ashiedu.ifeanyi@fupre.edu.ng, ²memetie@yahoo.com, ³agnesoboh@uniuyo.edu.ng

⁴samuel.david@fupre.edu.ng

Corresponding Author: ashiedu.ifeanyi@fupre.edu.ng

Abstract

Over the years, feather plucking of birds of all types and varieties are always done manually without specific attention to the health related challenges associated with such practices. Again, the quality of the processed birds and quantity required were not of interest. Today, the health implications, unit cost of de feathering, the quality and quantity of processed birds are of interest and paramount importance to farmers. Hence, this work is aimed at designing and manufacturing a modernized ergonomically friendly feather plucking machine using locally available materials. The method adopted for this research work include the selection of appropriate materials, including, hard wood for framing the machine, high density food grade plastic drum carefully manipulated to form the housing cavity. Other locally made materials used for the construction include, tapered plucking fingers made of rubbers, plastic pipes and fittings. Also, the desired electric motor to drive the system using appropriate pulleys and belts were selected using appropriate mathematical models. Result showed that at an operating speed of 300 rpm, birds with average weight of 1.5 kg soaked in water for about 85 degrees Celsius for 6 minutes were de feathered in 20 seconds. Other results showed that the weight, temperature of the water, the speed of the motor and the duration of soaking of the bird in water were all important variables to be addressed to enhance the efficiency of the machine and the quality of dressed birds.

Key words: de feathering, machine, birds, temperature, rubber pluckers

1.0 Introduction

Marfes farms Nigeria limited is an industrial agricultural setting located in Issele-uku, the administrative head quarter of Aniocha North Local Government area of Delta State, Nigeria. The farm is devoted to hatching, raising and managing all kinds of poultry birds for commercial purposes. More recently, the demand for dressed birds is on the increase. The management of the farm therefore deemed it necessary to produce a feather plucking machine to enable them meets up with the upsurge in the demand of dressed birds on one hand and to also exploit the possibility of exporting the dressed birds on the other hand. This research work is therefore concerned with the development of a feather plucking machine using the available local raw materials where possible. The work is important in that it will solve the problem of manual plucking of feathers which is often associated with health challenges due to the unhygienic way in which they are handled most times. It is also relevant in the sense that more time, energy and loss of manual labour (man hour) will

be saved thus increasing productivity which in turn increases the profit margin of the firm. To this end, search conducted revealed that most researchers in the developed nations of the world had worked in this area extensively. A good example includes Barbut (1998) who in his work estimated the magnitude of the problems associated with poultry processing system. Also, Dickson and Shackelford (1998) investigated the stunning time, scalding time and scalding temperature with respect to feather releasing forces associated with some types of birds. Similarly, Pitchovsci et al. (1997) identified the starting point of breast skin tear during plucking and x-rayed how the problem can be avoided using the best temperature and time merging for soaking of the individual birds.

In the tropical West Africa region, including Nigeria, not much had been done in this research area. However, Adetola et al. (2014) designed and developed a household poultry de-feathering machine for boilers. The paper observed that tearing of the carcass during plucking process is the major problem associated with bird dressing; the paper however added that this problem was

taken into account during the design process of the developed machine. In a related work, Jekayinfa (2005) carried out a general energetic analysis of poultry processing operatives with a view of recommending the desired range of operations with respect to the type of birds, temperature range and the soaking time. Also, Adejumo et al. (2013) evaluated a feather plucking machine using two breeds of birds namely Isa brown and Cockerel at machine speed of 225, 312, 369 and 426 rpm. With a scalding time of 30, 60 and 90 seconds respectively. The result of the work showed that the developed machine performed better when the speed was increased with cockerel having the better plucking result. Also, Adeyinka and Olawale (2015) carried out performance evaluation of chicken de-feathering machine for small scale farmers. The paper observed that it took the machine about 25 seconds to de-feather poultry birds with a machine speed of 300 rpm. However, the paper failed to indicate the specie, type and age of birds that were evaluated.

In a related development, Adetola et al. (2012) considered birds raised in South Western Nigeria with a view to establishing the optimal scalding temperatures of both the exotic and local breeds. The result of their finding showed that for local breeds,

the scalding temperature of 80⁰C – 85⁰C is adequate, while those of the exotic breed falls between 65⁰C to 70⁰C.

Also, Ugwu et al. (2015) carried out optimization and performance evaluation of a developed feather plucking machine. The result obtained in the study showed that at 400 rpm the machine was able to pluck completely at an average time of 22.8 seconds. The paper added that the speed of the machine and the species of poultry birds affects the efficiency of the machines.

In south-western Nigeria, Taniomola et al. (2011) designed and developed a bird de – feathering machine capable of de – feathering 360 mature birds in an hour, irrespective of the type of bird involved. The paper added that the machine recorded about 96 percent when tested with under controlled condition. Elsewhere, Nguyen et al. (2011) investigated the optimal operational parameters for a chicken slaughtering system in Vietnam. The paper recommended an optimal scalding temperature of about 67 degree Celcius and an optimum scalding time of 80 seconds. Again, Irshad and Arun (2013) studied the pathogenic and non-pathogenic micro-organism introduced into the system during scalding. The paper added that the micro-

organism is found in the internal and external surface of the carcass in addition to the ones found in the scalding water. The paper added that it is very important to rinse the birds in warm water so as to remove all

traces of blood in the carcass. By so doing, most of the micro – organism will be washed and rendered inactive.

Materials and Methods

The old layer grade bird was selected for this experiment. The choice of old layer was anchored on the fact that Marfes Farms principally breed and raise this type of birds in commercial quantity for both national and international trade. Other locally made materials considered for this design include, though not limited to;

- High density grade plastic
- Assorted types of hard wood for the frame
- Tapered plucking fingers used as puckers in the cabin
- Steel materials used for making of the shaft and fabrication of other necessary parts.

- Electric motors, pipes and fittings.

Since the primary aim of de- feathering is to provide quality birds for both export and domestic uses, effort is made to select locally available materials for its construction bearing in mind the following;

- The safety of the edible birds and the machine operator
- Availability of the materials for production when the need arises
- The ease of operation and alteration of the system and the various machine components
- The durability, availability and reliability of the selected materials at all times and
- The economics in the ergonomics of making modern de – feathering machines.

Basic Design Calculations

Volume of the plucking chamber

Since the plucking chamber is shaped like a frustum, the volume of the chamber can be obtained using;

$$\frac{(\quad)}{\quad}$$

Where, V , is the volume of the plucking chamber, R is the radius of the upper opening of the drum, r is the radius of the base of the plucking chamber and h is the

height of the chamber. Recall that the upper diameter, base diameter and height of the chamber have been stated to be 0.5m, 0.4m and 0.7 respectively.

Hence

$$\frac{(\quad)}{\quad}$$

Speed of the rotating member

The speed of the rotating drum can be calculated using

—

—

Force required for the feather removal

The force required for the feather removal is given by;

Where, is the mass of the rotating pulley , , is the radius of the motor pulley-0.007m,

Where

,

and

Given that; and

Hence

—

(3.3)

—————

Where

—

Assuming N to be 1285 RPM

—————

Hence

i.e.

In designing the shaft, the diameter of the rotating shaft is calculated using

$$d = \sqrt[3]{\frac{16 T K_f}{\pi \tau}}$$

Where,

K_f is the combined shock and fatigue factor applied to torsional moment, T is the bending moment, τ and d is the allowable shear stress

Shear failure analysis of the de-feathering chamber

The shear stress of the de-feathering chamber is determined by the equation;

2.2.1 Power requirement of the machine

The total power () requirement of the machine is the sum of the power required to rotate the feather plate () and the power required to de-feather () the chicken. It is given as;

$$P_{total} = P_{rotate} + P_{de-feather}$$

Power required to rotate the feather plate

The power required to rotate the feather plate is determined by the equation;

Where, W is the weight of the rotating plate- 5N, ω is the angular velocity of the rotating

plate. The speed used is the electric motor speed i.e. 1400RPM.

Power required to rotate the feather plate

() () ()

Power required to de-feather

But

—

Where, is the power required to de-feather the bird, is the torque of the de-feathering chamber, is the angular velocity of the de-feathering chamber = —, D= mean diameter of the de-feathering chamber,

—————

Therefore, the power required to de-feather the bird

Since 1Hp is 0.746KW, the total power in horsepower will be 5.18HP.

An electric motor of 1Hp can conveniently power the machine.

An electric motor of 1Hp can conveniently power the machine

The pictorial view of the feather plucking machine as designed and developed is presented in figure 1. The description of the components used for the fabrication followed thereof. It is quite important to state here that all these components were sourced locally; this is to justify the local content requirements of indigenous developed engineering systems for use locally.

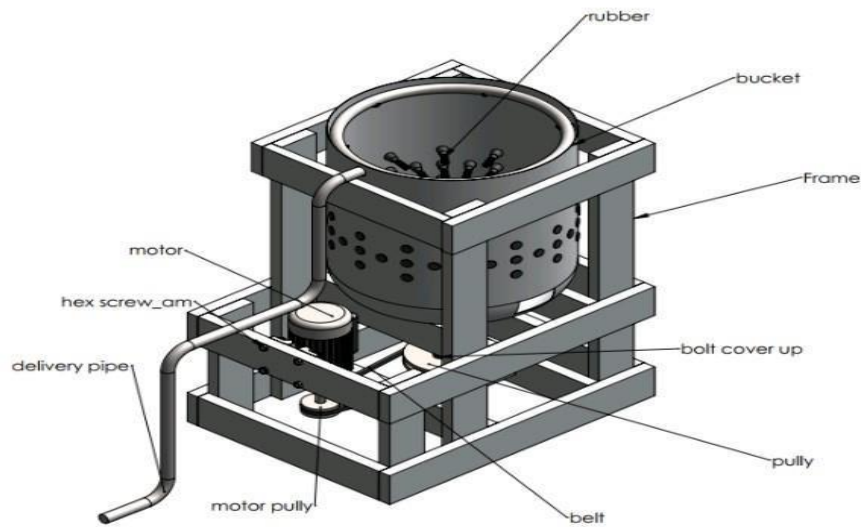

Figure 1: solid work diagram of the developed feather plucking machine.

Figure 1 show a schematic diagram of the developed feather plucking machine, the improved machine is made up of, one horse power electric motor to drive the pulley, a belt adequately selected, a cylindrical

structure of 25 mm in diameter, wooden members to provide rigid structures and peeler fingers to aid the removal of the feathers



Figure 2.0: Different component used in fabrication of feather plucking machine.

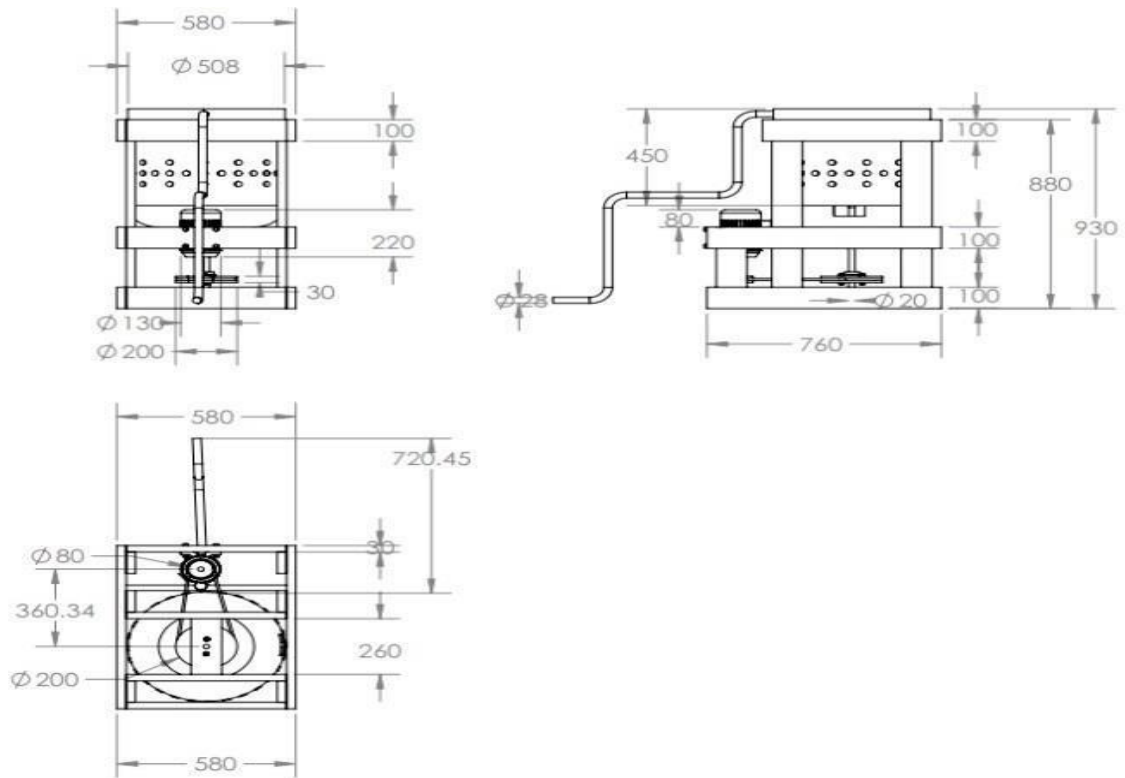

Figure 3.0: 2-d drawing of the feather plucking machine.

3. Results and Discussion

The result of the test carried out using the old layer breeds at a soaking temperature of 80 to 90 degree Celsius for an average time of 10 minutes showed that at different speeds of motor, the efficiency and the effectiveness of the machine varies with respect to the quality of cleaned carcass produced. It was also observed that at an

average speed of 300 revolutions per minute, it takes the machine about 30 seconds to completely de feather an old layer breeds of bird of about 1.2 Kg weight. However, test carried out on exotic birds showed that the machine was less effective, because of the weight and the speed of the rotating members. As a result of this observation, the speed of the machine was varied to 400 revolutions per minute, using

an average bird weight of 2.5 kg of exotic birds. The major difference between the exotic, the old layer birds and the local breed birds is that it takes less time (about 20 seconds) to de feather completely, at an immersion time of 3 minutes at water temperature of about 60 degrees Celsius. It was equally observed that the higher the speed, the faster the process of feather removal, however, at some speed, the carcass was seen to have some tear and wounds all over the birds making them look nasty, unpleasant, unattractive and dirty in some cases. . During this study, the authors observed that the birds must be totally submerged in hot water (of about 60 – 80 °C), depending on the type, specie and age of the birds. This is important, so that the most firmly attached feathers, such as those on the tails and the neck region will be properly soaked to aid dilation for easy removal. It is therefore, the desire of the authors to research further into the desired optimal operational speed and temperatures of immersion of some selected breeds of table birds to compliment this work, with a view to recommending the appropriate speed of machine, the desired water temperature for different breeds of birds, the total immersion time and any other variable that may aid an effective de feathering

process. This is important and necessary, because the federal government position on imported frozen food such as chicken will encourage local production that meets international standard for both consumption and exportation. when this is done effectively, the gross domestic product of our country Nigeria will be affected positively, which will in turn promote the average living standard of an average Nigerians.

Conclusion

A locally made feather removing machine with an efficiency of 76 % has been conceived, designed and manufactured, to replace the crude method of manually removing birds' feather under the most unhygienic conditions in Marfes Farms Nig. It is our view that the major users of this machine will find it easy and convenient since it requires no special training for the intended users. This undoubtedly will boost production, increase profit margin and ultimately increase productivity most especially now that the Federal Government of Nigeria is more interested in commercial agricultural practices than ever. However, it is of interest to note that this machine is specifically designed for birds that weighs 1.5 Kg and below. More so, our findings

showed that it takes more time (about 5 minutes) to completely de-feather old layers and cockerels of the same weight with broilers. This means that the feathers of the old layers and the cockerels are more firmly attached, tougher and harder to remove. Again, the processing temperature requirement about 70° C and the required dipping time of 5 minutes for old layers and cockerels differ from those of the broilers table birds. This is predominantly so, because the broilers skin is so soft and tender, hence needed to be treated with utmost care to meet international standard. However, it is instructive to point out here that the workers in Marfes farms were not really happy and interested in using the

machine owing principally to fear of job loss if accepted. Having discovered this, their fears were cut short by proper briefing and de briefing on the applications and use of the machine for faster, efficient, improved and hygienic way of processing birds to meet international standard. Again, instead of the perceived cut in workforce, the management of the Farm, employed more workers, train them on the use of the machines so as to meet up with delivery targets. The test so far conducted using the machine showed a significant departure from the old crude way of processing birds to an improved, efficient and standard way of de feathering poultry birds.

References

- Adeyinka A.A. and Olawale J.O. (2015). Development and performance Evaluation of a chicken De-feathering machine for small scale farmers. *Journal of advanced Agricultural Technologies* 2(1): 71-74.
- Adetola S.O, Daramola G.A and Ogundiran S.O (2014). Development of a Household Poultry De-feathering machine with Better Efficiency. *Journal of Mechanical and Civil Engineering (IBSR-JMCE)* 2(3):51-59.
- Adetola S.O, Onawumi A.S and Lucas E.B (2012). Investigation into Mechanized De-feathering process and optimal scalding temperatures of exotic and local birds in Southern Nigeria. *Transnational Journal of Science and Technology* 2(3): 87-96.
- Adejumo A.O.D, Adegbite A.M, Brai S, Oni O.V and Opadijo O.O. (2013). The Effects of Machine and Poultry Parameters on Feather Plucking. *International Journal of Engineering Research and Applications* 3(6):161-166.
- Barbut S. (1998). Estimating the magnitude of the PSE problem in poultry.

- Journal Muscle Food, 9(5):119-207.
- Dickson J.A. and Shackelford (1998). Feather-releasing force related to stunning, scalding time and scalding temperature. Poultry Science 67(5): 1069- 104
- Irshad, A and Arun, T. S (2013). Scalding and its Significance in Livestock Slaughter and Wholesome Meat Production. International Journal of Livestock Research 3(2): 45 – 53.
- Lucas E.B and Adetola S.O (2013). Comparative plucking force characterization of Chicken produced from two Breeds of Chicken. International Journal of Engineering and Applications 3(4): 53-579.
- Nguyen, V. H, Doan, H. M and Dang, T. S. (2011). An Investigation of Optimal Operational Parameters for a Slaughtering System in Vietnam. International Transaction Journal of Engineering Management, Applied Sciences and Technology 4(4): 423 436.
- Rogers, D. J and Don, R. S. (2003). Procedures for Killing and Dressing Home Grown Fowl. Institute of Food and Agricultural Sciences, University of Florida, Gainesville, FL 32611.
- Tanimola, O. A, Diabana, P. D and Bankole, Y. O (2014) Design and Development of a De – Feathering Machine. International Journal of Scientific and Engineering Research 5(6):208 214.
- Ugwu K.C, Agu S.O. and Ogbuagu N.J (2015). Optimisation and Performance Evaluation of Chicken Feather Plucking Machine. International Journal of Science and Engineering Research 6(7):102-108.